

Megadoor S1500 Vertical fabric folding door

Product datasheet



Copyright and Disclaimer Notice

Although the contents of this publication have been compiled with the greatest possible care, ASSA ABLOY Entrance Systems cannot accept liability for any damage that might arise from errors or omissions in this publication. We also reserve the right to make appropriate technical modifications/replacements without prior notice. No rights can be derived from the contents of this document.

Color guides: Color differences may occur due to different printing and publication methods.

ASSA ABLOY, Crawford, Megadoor and hafa, as words and logos, are examples of trademarks owned by ASSA ABLOY Entrance Systems or companies within the ASSA ABLOY Group.

Copyright © ASSA ABLOY Entrance Systems 2006-2011

No part of this publication may be copied or published by means of scanning, printing, photocopying, microfilm or any other process whatsoever without prior permission in writing by ASSA ABLOY Entrance Systems.

All rights reserved

Technical facts

Features

Max size: (W/H) depending on wind load*	19000 mm/20000 mm
Door leaf thickness:	290 mm
Fabric types:	Standard: Polyester (coating: plasticized PVC) Options: Arctic, sound reduction, heat resistant, security
Color:	9 standard RAL colors
Guide rails material:	Aluminium
Windows:	Vision panels (width 800 mm standard)
Seals:	Bottom, side and top seal
Operation:	Standard: Drive Unit Optional: Automated operation, Access control, Safety functions

*Other sizes available on request.

Note! For larger openings, see Megadoor Special Doors with virtually no size limitations other than what is practical.

Megadoor Special Doors can be delivered as large single belt doors (with 2-motor drive), large single wire rope doors or multiple door systems.

Performance

Operating speed:	0.15 - 0.25 m/s
Wind load resistance: (differential pressure)	Can withstand almost any wind load by varying the size and the spacing of the intermediate sections.
Wind speed, door in motion:	< 20 m/s
Sound reduction (standard):	15 dB Rw (ISO 717)
Water resistance:	Class 3 (EN 12425, 0.11 kPa for closed door)
Air permeability:	Class 2 – 4 (EN 12426) Depending on door size. Specific data on request.
Operating environment temperature range:	-35°C to +70°C
Thermal transmittance:	Depending on door size. Specific data on request.

Contents

Copyright and Disclaimer Notice.....	ii
Technical facts.....	iii
Features.....	iii
Performance.....	iii
1. Description.....	5
1.1 General.....	5
1.2 Standard.....	5
1.3 Options.....	5
1.4 Door leaf.....	6
1.4.1 Construction.....	6
1.4.2 Intermediate section.....	6
1.4.3 Bottom section.....	6
1.4.4 Safety arresters.....	6
1.4.5 Wind locking.....	7
1.4.6 Door leaf material.....	7
1.4.7 Colors.....	7
1.4.8 Options.....	8
1.5 Guide rails.....	8
1.6 Header box.....	8
Header box options.....	8
1.6.2 Enclosing the header box.....	9
1.7 Operating system.....	9
1.7.1 Electrical operation.....	9
1.7.2 Lifting belts.....	10
1.7.3 Drive unit.....	10
1.7.4 Control unit.....	10
1.7.5 PLC.....	10
1.7.6 Heating Element.....	10
2. Specifications.....	11
2.1 Clear width and clear height.....	11
2.2 Performance.....	11
2.3 Environmental tolerance.....	11
2.4 Surface treatment.....	11
2.5 Door leaf.....	12
2.5.1 Fabric data.....	12
2.6 Operating system.....	15
2.6.1 General specifications.....	15
3. CEN Performance.....	16
3.1 Resistance to windload.....	16
3.2 Additional tests.....	16
4. Building preparations.....	17
4.1 Installation.....	17
4.1.1 Installation of the header box.....	17
4.1.2 Mounting surface for header box.....	19
4.2 Mounting surface for guide rails.....	20
4.2.1 Mounting alternatives for guide rails.....	20
4.3 Installation of the guide rails.....	21
4.3.1 Installation of the control unit.....	21
4.4 Space requirements.....	21
4.5 Spare requirements for header box.....	21
4.6 Space requirements for operation.....	22
4.7 Space requirements for control unit.....	22
4.8 Space requirements for maintenance.....	23
5. Index.....	24



1. Description

1.1 General

The Megadoor S1500 vertical fabric folding door is the preferred door model for the extremely large door openings needed for aircraft hangars and shipyard halls, it serves equally well in any door application where innovative design will make a positive difference to the construction cost and subsequent operating efficiency.

The unique design and structure offers durability, tightness, energy efficiency, operational reliability and minimum maintenance. Every door is individually designed to meet application requirements, for example wind load.

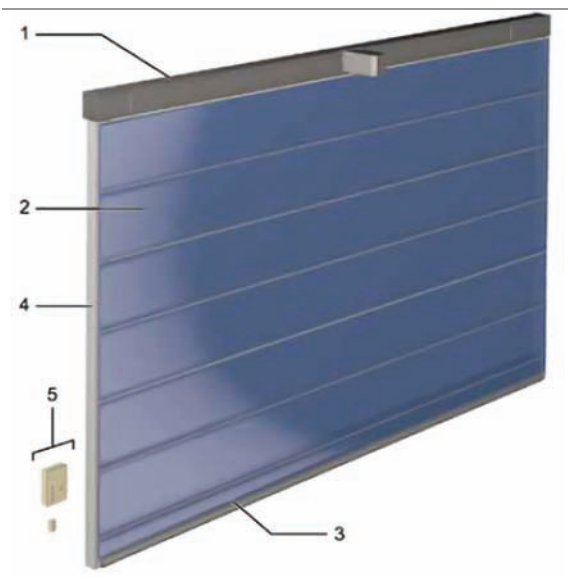

The Megadoor S1500 vertical fabric folding door has five main components:

1. Header box
2. Door leaf
3. Bottom section
4. Guide rails
5. Control cabinet

1.2 Standard

The Megadoor S1500 vertical fabric folding door is supplied with the following specifications as standard:

Door leaf:	Polyester, 1100 dtex with plasticised PVC coating
Safety:	Safety arresters
Operation:	Drive unit + control unit
Colors:	Choice of 9 standard RAL colors

1.3 Options

Megadoor provides a wide range of options and accessories to customise the Megadoor S1500 vertical fabric folding door to any customer's needs. For example:

Door leaf:	Arctic, heat resistant, sound reduction and security fabrics Vision panels Clamp strip covers
Header box:	Protective cladding
Colors:	Optional colors on request
Operation:	Automation

1.4 Door leaf

1.4.1 Construction

The door leaf is made of two layers of very strong vinyl-coated polyester fabric, separated by aluminium intermediate sections. The aluminium top section is bolted to the header box, the steel and aluminium bottom section is connected to the lifting belt via the safety arresters.

The fabric is attached to both sides of the intermediate sections, top section and bottom section with self-tapping screws through aluminium clamp strips, providing maximum tightness.

Wind load is transferred to the vertical guide rails by the horizontal aluminium sections of the door leaf.

1.4.2 Intermediate section

The intermediate sections, which are made of extruded aluminium, are fitted at each end with lubrication-free guide blocks, which travel in the guide rails on each side of the door leaf. The section depth is 290 mm for the System 1500 with belt operation.

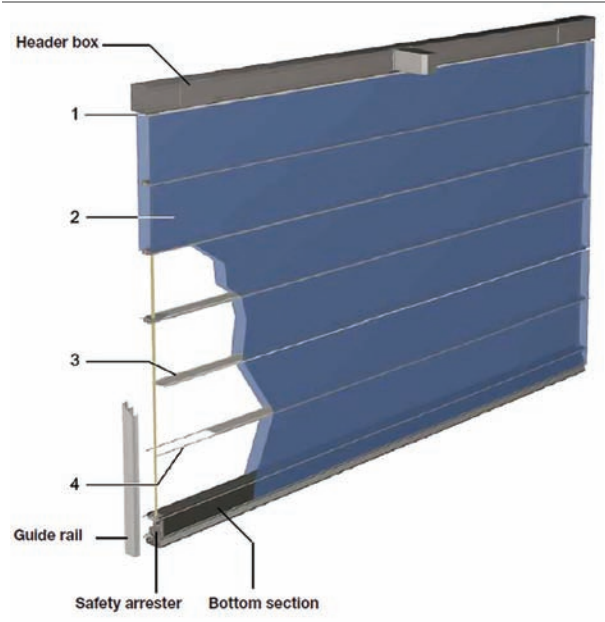

1.4.3 Bottom section

The bottom section is made of steel. A rubber seal fixed to the section ensures tightness against the floor/ground.

1.4.4 Safety arresters

The lifting belts are attached to the patented safety arresters, which in turn are fixed to the bottom section. In the unlikely event of a belt failure, the safety arresters are activated and immediately lock the door in the guide rails.

The safety function is tested and certified by TÜV.

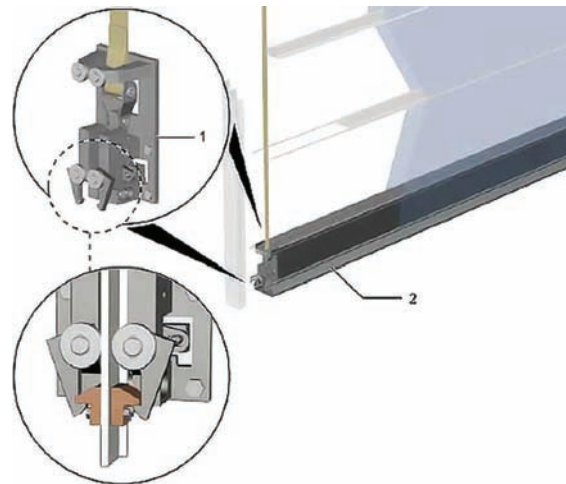

Wind locking

Bottom section:
1. Safety arrester
2. Rubber seal



1.4.5 Wind locking

Strong winds subject a large door to a substantial load. Megadoor safety arresters therefore have a unique built-in wind locking, which is activated and locks the bottom beam when the door is closed.

1.4.6 Door leaf material

Standard Fabric

The standard door-leaf fabric is a single sheet of heavy-duty vinyl-coated polyester. The fabric is resistant to mechanical abrasion and sparks generated from mechanical processes such as welding.

The standard fabric is available in 9 standard RAL colors, however other colors are available on request.

Arctic Fabric

The arctic fabric replaces the standard fabric in environments where the temperature can be as low as -45°C. It is only available in blue (RAL 5005).

Sound-reduction Fabric

The sound-reduction fabric is for use in environments where the transmission of sound through the door must be reduced. It is installed on both sides of the door leaf.

Heat-resistant Fabric

The heat-resistant fabric replaces the standard fabric on the inside of the door leaf when there is a requirement to contain heat and/or chemical hazards. It is available with three different coatings dependant on the environment where it is going to be used.

Security Fabric

The security fabric is for use in environments where security is important. It is similar to the standard fabric with the addition of galvanized steel wires inside the fabric. It is installed on both sides of the door leaf behind the standard fabric.







Vision Panels

Vision panels (windows) are available for the standard and arctic fabrics to improve light admission and visibility through the door leaf.

1.4.7 Colors

The RAL-colors are as close as possible to the official RAL HR collection.

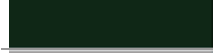
1.4.7.1 Standard colors

	RAL 1001	Tan
	RAL 1003	Yellow
	RAL 3001	Red
	RAL 5005	Blue
	RAL 6009	Green
	RAL 7004	Grey
	RAL 7016	Anthracite grey
	RAL 9016	White
		Translucent white

1.4.7.2 Optional colors

Other colors are available on request

1.4.8 Options

Clamp strip covers

Clamp strip covers are plastic strips that clip onto the clamp strips. They are available in the same standard colors as the fabric.

The benefits of the clamp strip covers are:

- Improve the appearance of the door leaf
- Cover the screws
- Protect the door leaf from discoloration in certain environments.

1.5 Guide rails

The extruded guide rails are made up of three parts, a rail surrounded by two outer sections. The guide blocks in the intermediate sections travel along the guide rail and guide the door. The design of the guide rails ensures that air leaks are minimised.

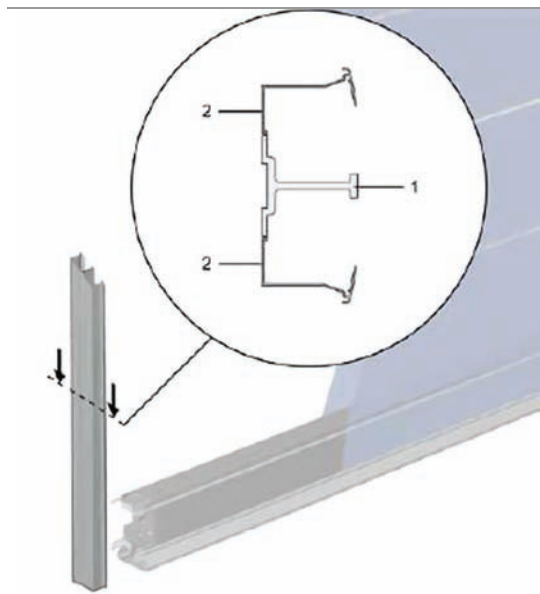

Guide rail
1. Guide rail
2. Seal angle

1.6 Header box

The door leaf with the bottom section is suspended by a firm box structure of steel, which contains the drive unit and limit switch units with position sensors and devices for checking belt status.

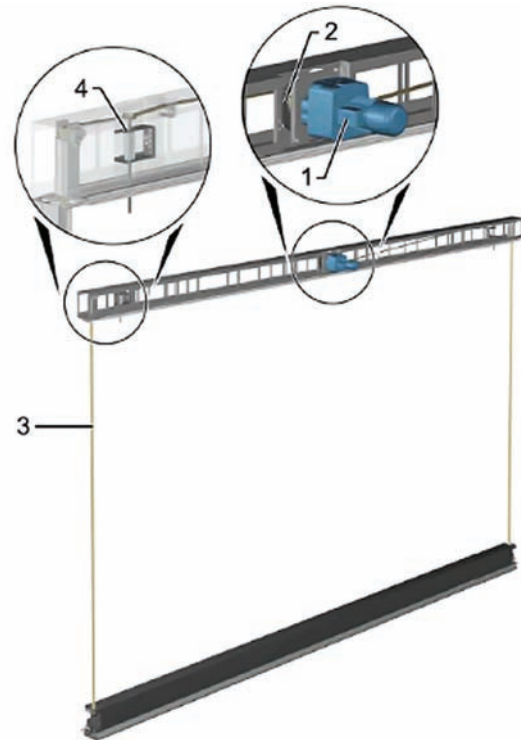

Header box
1. Drive unit
2. Belt drum
3. Lifting belt
4. Limit switching units

Header box options

1.6.1.1 Dust proof limit switch boxes

An optional dust-proof limit-switch box (IP64) replaces the standard limit-switch box. This provides full protection from dry particles of any size.



1.6.1.2 Heater in limit switch boxes

In environments with very low and variable temperatures where humidity is high, it is recommended to use heaters to avoid moisture inside the limit-switch boxes.

1.6.2 Enclosing the header box

1.6.2.1 Enclosed motor side

The door is delivered as standard with the motor side enclosed. Components that need to be accessible for inspection are located at the ends of the header box behind hatches. The rest of the header box has a removable sheet-steel enclosure between the hatches.

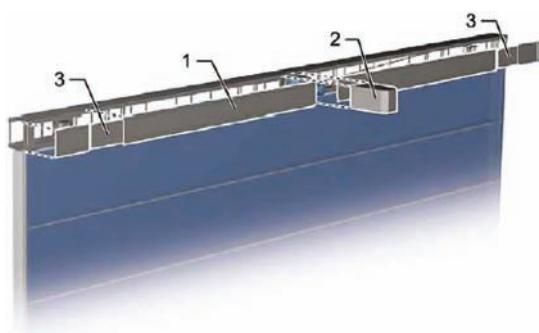

Enclosure

1. Enclosed motor side (standard)
2. Protective casing (extra)
3. Inspection hatches (standard)

1.6.2.2 Enclosed "non-motor side" (extra)

For fitting in a door opening, with the drive unit facing inwards, the "non-motor side" should be fitted with a fixed sheet-metal cover. Inspection is done from the motor side.

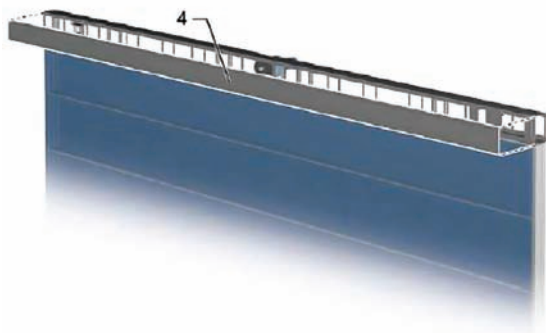

4. Enclosed "non-motor side" (extra)

1.6.2.3 Protective casing over motor (extra)

For outdoor fitting or in dirty environments, the motor should be fully protected. The protective casing is made of powder coated steel sheet. The casing is provided with a hatch to facilitate easy access to the motor for possible manual emergency operation if required. The entire cover can be removed.

1.7 Operating system

1.7.1 Electrical operation

The Megadoor S1500 Vertical fabric folding door is always supplied with an electrical operating system, a control unit near the door and a gear motor in the header box.

The door is opened by an impulse from the UP-button.

The door is closed by pressing the DOWN-button continuously (Hold to run).

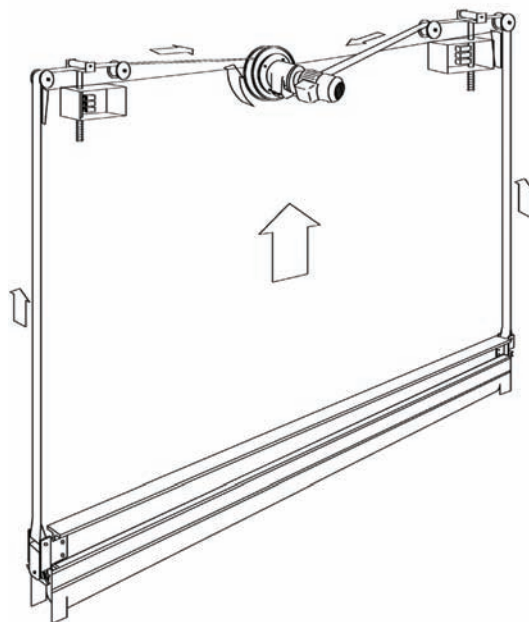

1.7.2 Lifting belts

The bottom section is lifted using belts, which are wound up on the belt drum. The belts are fitted with sewn loops for attachment to the safety arresters. The belts are not sensitive to rust, dirt and dust, and are tested and certified.

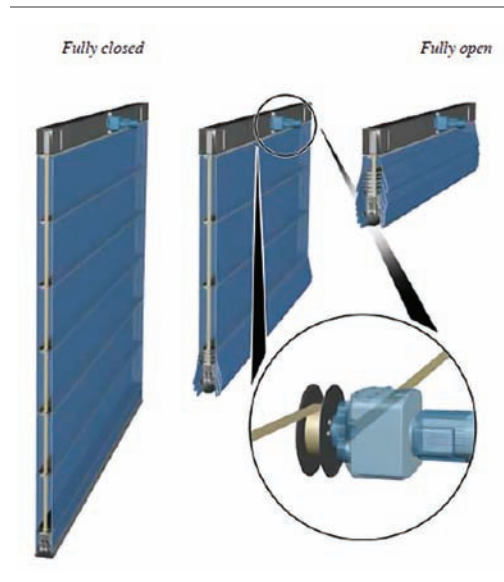

1.7.3 Drive unit

The gear motor, which is equipped with a brake, also has a hand-operated brake release and crank, so that the door can be opened or closed in the event of a power failure. The belt drum is directly mounted with a keyed joint on the output shaft of the gear motor.

1.7.4 Control unit

The door is supplied with a PLC-based control unit installed near the door. The control unit commands the gear motor via push buttons.



The UP button opens the door by impulse signal. The DOWN button is set to hold-to-run. The gear motor can be disabled from the control unit for emergency hand-crank operation by switching off the mains.

1.7.5 PLC

The control unit contains a PLC for the setting of timers, automatic and safety functions. The PLC is programmed and configured before delivery. The menu gives the following information:

- Number of days of operation and number of door openings from the start since the door was last serviced.
- Current settings
- Diagnostics

1.7.6 Heating Element

An optional heating element can be installed in the control unit, to avoid moisture inside the unit at low and variable temperatures and in moist air.

2. Specifications

2.1 Clear width and clear height

The standard Megadoor S1500 vertical fabric folding door is delivered in the following size range:

Max size: (W/H) depending on wind load.*	19000 mm / 20000 mm
--	---------------------

*Other sizes available on request.

Note! For larger openings, see Megadoor Special Doors with virtually no size limitations other than what is practical.

Megadoor Special Doors can be delivered as large single belt doors (with 2-motor drive), large single wire rope doors or multiple door systems.

2.2 Performance

Door leaf thickness	290 mm
Nominal opening speed	0.15 - 0.25m/s
Resistance to wind load/standard differential pressure (higher wind load resistance on request)	Can withstand almost any wind load by varying the size and the spacing of the intermediate sections.
Water resistance	Class 3 (EN 12425, 0.11 kPa for closed door)
Thermal transmittance	Depending on door size. Specific data on request.
Air permeability	Class 2 – 4 (EN 12426) Depending on door size. Specific data on request.
Sound reduction	15 dB Rw, acc. to ISO 717

2.3 Environmental tolerance

Heat and cold resistance	-35°C to +70°C
Atmospheric humidity	below dew point
Presence of particles	< 1000 µg/m ³ air
Mechanical load, blasting	Not directly aimed.
Differential pressure, closed door	Class 3 (EN12424, temporary 0.7 kPa)
Wind speed, in motion	< 20 m/s
Acidity	Condensate at 5<pH<9
Explosive fumes or dust	No occurrence.

*In the normal version, the door is suited for operation in environments within the limits stated above. If the requirements exceed these limits (e.g. wind load), the door can often be modified on request.

2.4 Surface treatment

Steel components	For corrosion, category 3 according to ISO 12944.2. Higher class on request.
Other parts	Aluminium, plastic, stainless steel, zinc electroplated steel (~ 10µ). Fixing elements are mainly hot dip galvanized (FZV). Door leaf screws are corrosion protected with Geomet.

2.5 Door leaf

2.5.1 Fabric data

2.5.1.1 Standard fabric

Application	Standard		
Use	Standard		
Coating	Plasticized PVC		
Fabric	Polyester, 1100 dtex		
Weight	700 g/m ²		
Heat- and cold resistance	-35°C to +70°C		
Tensile strength	Warp : 2700N/5 cm acc. DIN 53354, EN ISO 1421 Weft : 2500N/5 cm acc. DIN 53354, EN ISO 1421		
Tear resistance	Warp : 370N acc. DIN 53363 Weft : 320N acc. DIN 53363		
Resistance to light	6 - 8 (on a scale 0-8) acc. BS 1006 > 7 acc. ISO 105-B02		
UV-stabilized	Yes		
Flame resistant	Yes, acc. SIS 650082, ASTM E84-94 class A, DIN 4102 B1		
Mildew resistant	Yes		
Rot resistant	Yes		
Radar reflection	0.3 dB, - 0.1%		
Lacquered	Yes		
Standard colors	<ul style="list-style-type: none"> • Tan • Yellow • Red • Blue • Green • Grey • Anthracite grey • White • Translucent white 	<ul style="list-style-type: none"> NCS 2010Y-40R NCS S0570-Y20R NCS 2070-R NCS S3560-R80B NCS 8010-G10Y NCS 3500 NCS 8005-B20G NCS 0500 	<ul style="list-style-type: none"> RAL 1001 RAL 1003 RAL 3001 RAL 5005 RAL 6009 RAL 7004 RAL 7016 RAL 9016
Logotype	Optional		
Vision panels	Optional		

2.5.1.2 Arctic fabric

Application	Environmental temperatures down to -45°C		
Use	Replaces standard fabric		
Coating	PVC/PU (mixed)		
Fabric	Polyester, 1100 dtex		
Weight	680 g/m ²		
Heat- and cold resistance	-45°C to +70°C, acc. SFS-EN 1876-1		
Tensile strength	Warp : 3000N/5 cm acc. DIN 53354 Weft : 3000N/5 cm acc. DIN 53354		
Tear resistance	Warp : 350N acc. DIN 53356 Weft : 300N acc. DIN 53356		
Resistance to light	6 - 8 (on a scale 0-8) acc. BS 1006		
UV-stabilized	Yes		
Flame resistant	Acc. DIN 75200		
Mildew resistant	Yes		
Rot resistant	Yes		
Comment	Fabric color blue only, RAL 5010		

2.5.1.3 Sound reduction fabric

Application	Sound reduction
Use	On both sides of the door behind the standard fabric
Coating	Plasticized PVC
Fabric	Polyester, 1100 dtex
Weight	1850 g/m ²
Sound reduction (incl. standard fabric)	Index Rw23dB*, tested by SP Swedish National Testing and research Institute
Heat- and cold resistance	-30°C to +70°C, acc. SFS-EN 1876-1
Tensile strength	Warp : 3000N/5 cm acc. DIN 53354 Weft : 2900N/5 cm acc. DIN 53354
Tear resistance	Warp : 380N acc. DIN 53356 Weft : 300N acc. DIN 53356
Flame resistant	Acc. SIS 650082, DIN 4102-B1

Note! Must always be quoted by Megadoor.

* Weighted apparent sound reduction index acc. ISO 717-1. For more information, ask for SP-report P103341, dated 15 June 2001 'Determination of sound insulation of an industrial door according to SS-EN ISO-140-3:95'.

2.5.1.4 Heat resistant fabric - Silicone coating

Application	<ul style="list-style-type: none"> • Hot air environment • Coating highly resistant to chemicals • Dirt and oil repellent • Electrical insulation • Weatherproof, UV and oxidation resistant
Use	Replacing standard fabric
Designation	Alpha Maritex 3200-2-SS
Coating	Silicon rubber on both sides
Fabric	Woven glass fibre EC9-136
Weight	555 g/m ²
Heat- and cold resistance	Coating -36°C to +260°C
Tensile strength	Warp : 450N/ cm acc. DIN ISO 4606 Weft : 440N/cm acc. DIN ISO 4606
Flame resistance	Acc. BS 476:Part 7, 1971 Part 6, 1989, M0. BS6853:1987 App. B, IMO resolution A653 (16)
Approvals	<ul style="list-style-type: none"> • Lloyds: SVG/F92/110, SAS F970017 • Powergen 08/65/242, LUL E 1042 A3 • National Power 08/GS/259
Comments	<ul style="list-style-type: none"> • Never combine standard and heat resistant fabric (for example upper part of the door with standard and lower part of the door with heat resistant fabric). • Protect the bottom sealing with the fabric as well. • When the door is installed against a wall on the cool side, the folding space on the hot side must be increased by at least 100 mm to avoid fabric wear. • The motor should be placed on the cool side. A heat radiation shield below the motor may be necessary. • All cables must be protected. • The clear height should be as large as possible.

Note! Must always be quoted by Megadoor.

2.5.1.5 Heat resistant fabric - Aluminium coating

Application	Hot air and high radiation temperatures inside (e.g. foundries). Good heat reflection properties.
Use	On the inside of the door (never on the outside) replacing standard fabric.
Designation	332 AL-HT
Coating	Aluminium pigments on polyurethane adhesive on one side of the fabric.
Fabric	E-glass EC9-136 (cross twill)
Weight	490 g/m ²
Heat- and cold resistance	From contact coating +200°C (not continuously)
Tensile strength	Warp: 800N/cm acc. DIN 53857 T1 Weft: 500N/cm acc. DIN 53857 T1
Comments	<ul style="list-style-type: none"> • Never combine standard and heat resistant fabric (for example upper part of the door with standard and lower part of the door with heat resistant fabric). • Protect the bottom sealing with the fabric as well. • When the door is installed against a wall on the cool side, the folding space on the hot side must be increased by at least 100 mm to avoid fabric wear. • The motor should be placed on the cool side. A heat radiation shield below the motor may be necessary. • All cables must be protected. • The clear height should be as large as possible.

Note! Must always be quoted by Megadoor.

2.5.1.6 Heat resistant fabric - Polyurethane coating

Application	Fire barrier
Use	On the inside of the door (never on the outside) on the outside of the standard fabric.
Designation	Texo 640-1
Coating	Polyurethane based with functional filler.
Fabric	Woven glass fibre Klevo Glass Texo 640-1 L
Weight	675 g/m ²
Heat- and cold resistance	Coating -30°C to +200°C
Tensile strength	Warp : 600N/cm acc. DIN ISO 13934-1 Weft : 500N/cm acc. DIN ISO 13934-1
Comments	<ul style="list-style-type: none"> • Weight compensation on opposite side may be needed; check with Megadoor • Similar fabric without coating was tested in 1981 by SP Swedish National Testing and research Institute, fire laboratory. The door fulfilled the tightness and fire diffusion requirements acc. FIRE 005 for 43 min. 45 sec.

Note! Must always be quoted by Megadoor.

2.5.1.7 Security fabric

Application	Protection against burglary
Use	On both sides of the door, behind the standard fabric. Up to approx. 2 metres from floor
Designation	Protector Classic FR
Fabric	PVC coated
Reinforcement	Galvanized steel wires in four directions
Weight	950 g/m ²
Heat- and cold resistance	-30°C to +70°C
Flame resistant	M2, acc. NF P92-507 (French standard)
Comments	Space for fabric folding must be increased by 100 mm on each side of the door, to avoid fabric wear.

Note! Must always be quoted by Megadoor.

2.5.1.8 Vision panels

Application	Light admission and view through
Use	800 - 1600 mm sized windows for standard and arctic fabric only
Standard sizes	Width 800 or 1300 mm, height 800 or 1600 mm
Material	Elaston 064, 1 mm
Weight	1230 g/m ²
Hardness	77° shore acc. DIN 53505
Heat- and cold resistance	-30°C to +50°C
Tear resistance acc. DIN 53455	Along : 21 N/mm ² Crosswise : 20 N/mm ²

2.6 Operating system

2.6.1 General specifications

Control system	PLC-based
Protection class, control cabinet	IP65
Protection class, limit switches	IP65
Protection class, motor/brake	IP55/IP55
Protection class, push buttons	IP65
Power supply	3/phase 400V 50Hz *other alternatives available on request
Control voltage	24V AC
Fusing	20-25 A
Free contacts	6 for control of user functions
Heat and cold resistance	-35°C to +70°C
Motor ratings	1.6 - 5.5 kW
Number of motors	One (two for big single leaf belt doors.)

3. CEN Performance

The following tests have been carried out by the Swedish National Testing and Research Institute in Borås. For more detailed information and values, see ITT report: 0402-CDP-397301

3.1 Resistance to windload

Windload resistance:	Can withstand almost any wind load by varying the size and the spacing of the intermediate sections.
----------------------	--

3.2 Additional tests

Water penetration (closed door)	Class 3 (EN12425)
Air permeability	Class 2 (EN12426)

4. Building preparations

Megadoors are delivered for installation on site. To ensure efficient and quick fitting, the site must be prepared before the fitters arrive.

4.1 Installation

The doors can be easily adapted for several types of openings. The door leaf is compressed when opened and therefore takes up a minimum of space above the opening. The header box is screwed or welded. Alternatively it can be fixed with beam clamps to existing beams.

4.1.1 Installation of the header box

There are two basic methods for attaching Megadoors:

- Against a wall on the inside/outside of the opening
- In a door opening

4.1.1.1 Fitting against wall on inside/outside of opening

Internal mounting is recommended where there is available space. The drive machinery and guide rails will then be fully protected. Choose fitting on the outside of the opening if the environment in the building is harsh, or if there is insufficient space above the opening.

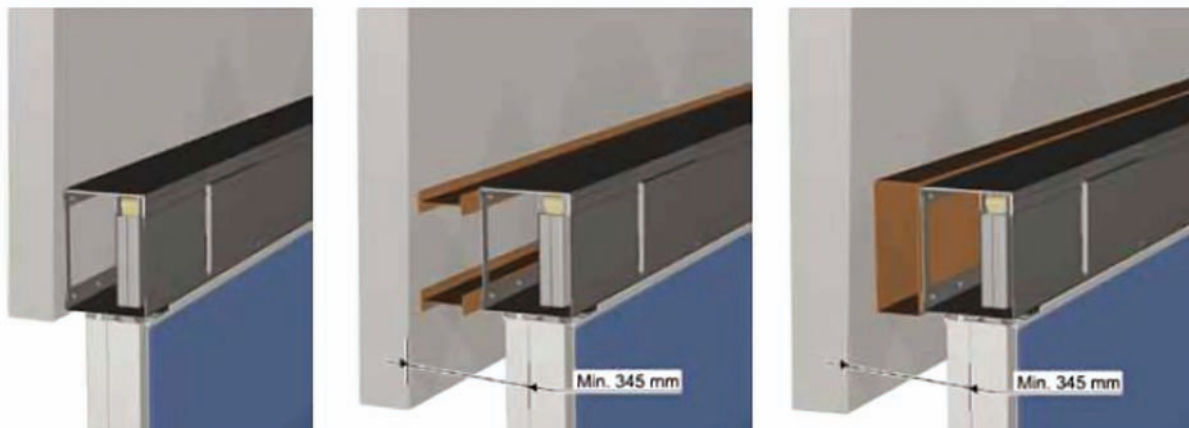

Fitting on wall against inside/outside of opening
N.B. Minimum 345 mm from wall to centre of guide rail
(85 mm from wall to rear side of header box).

4.1.1.2 Fitting in door opening

Mounting the door in an opening is an excellent alternative where the door is to be fitted in an existing opening and where the risk of colliding with the guide rails is negligible. It is also possible to protect the guide rails with a collision barrier.



Fitting in door opening (header box screwed, welded or fixed beam clamps).

4.1.1.3 Load on the building with door closed

When the door is closed, the total weight is distributed on the fixing points. The distance between fixing points is about 1 m and must not exceed 2.5 m. Information on the total weight of the door will be provided at the time of quotation.

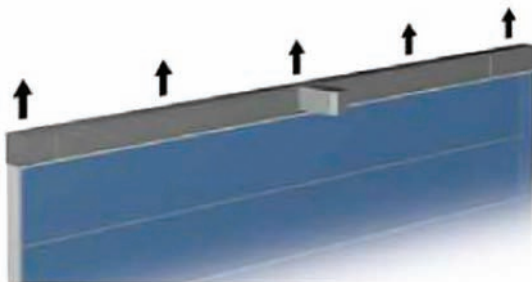

Load on building with door closed

4.1.1.4 Load on the building with door open

The weight of the door is successively transferred to the ends of the header box as the door is opened. When the door is fully open, the door leaf weighs on the ends of the header box only. The weight of the header box itself continues to rest on all the fixing points.

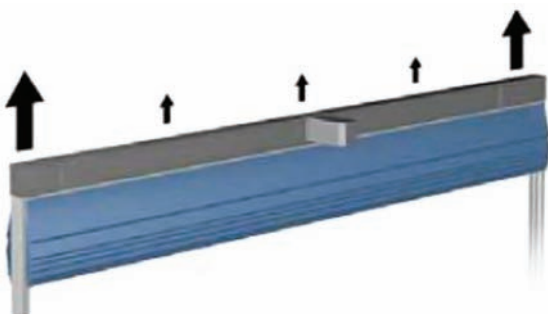

Load on building with door open

4.1.2 Mounting surface for header box

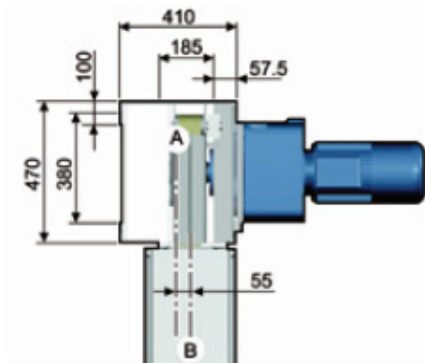

Screw holes in header box
A = Centre line header box
B = Centre line door leaf and guide rail

4.1.2.1 Mounting on wall (alt.1)

There must be flat, vertical surfaces to secure the header box (the part indicated as # 1).

4.1.2.2 Mount in opening (alt. 2)

There must be flat, horizontal surfaces to secure the header box (the part indicated as # 2).

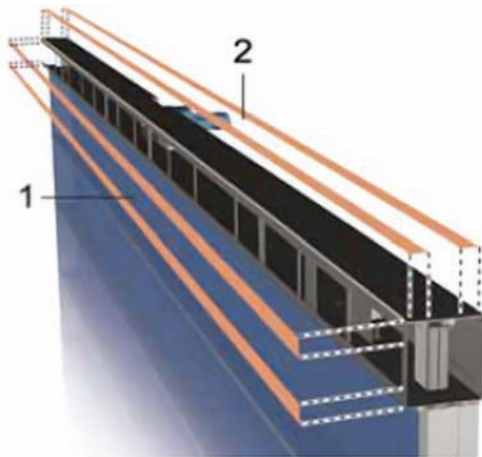

Mounting alternatives:
1. Fitting against wall
2. Fitting in opening

4.2 Mounting surface for guide rails

Suitable vertical surfaces are required on which to mount the guide rails. The mounting surfaces must be strong, flat and smooth. They must be parallel and deviate by no more than 5 mm from the vertical and by no more than 2 mm/m in the inward/outward direction from the vertical. The distance between fixing points is about 1 m.

N.B. Megadoor is not responsible for the calculation or supply of mounting surfaces, or for sealing between door and building.

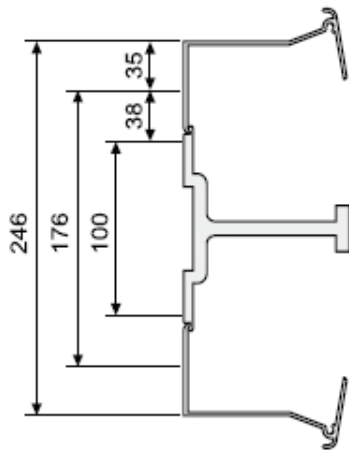

Screw hole distances in guide rails

4.2.1 Mounting alternatives for guide rails

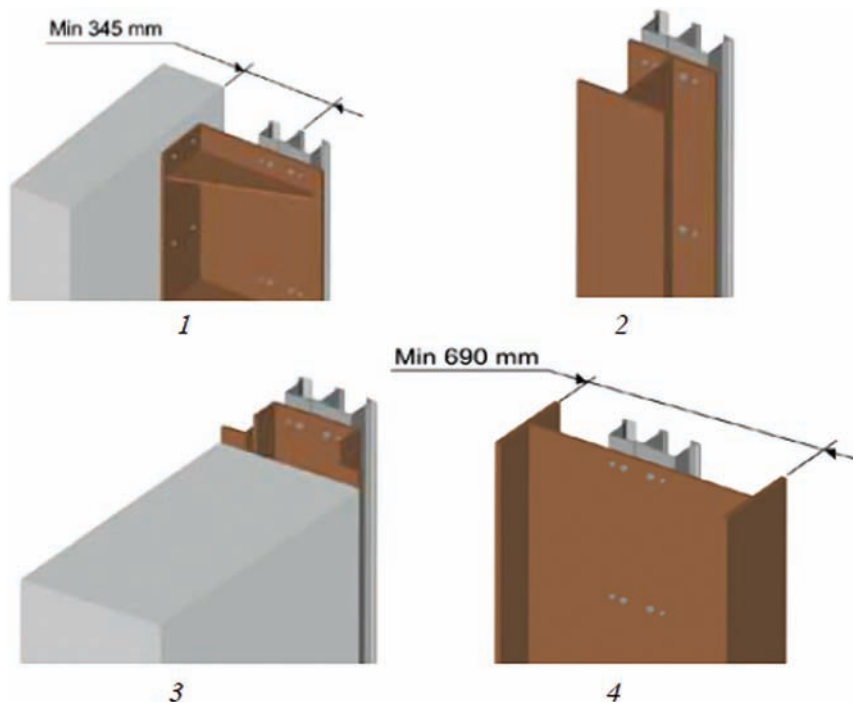

1. Fitting against wall.
- 2-4. Fitting in opening.



4.3 Installation of the guide rails

4.3.1 Installation of the control unit

The location of the control unit is best decided as follows:

Environment	Effect on control unit	Location of control unit
Normal environment	Negligible effect, IP65 protection is sufficient.	Close to the door
Harsh interior environment	When opened for maintenance, dust and moisture may enter	In a safe area
Sustainable temperature difference inside/outside	Condensation when door is opened	Away from the door. Push button unit close to the door
Strongly corrosive environment, no safe location possible	Optimum protection required	Stainless steel control unit

Also consider the space requirements of the control unit.

4.4 Space requirements

TH	Total height	Distance between floor and top of header box
CH	Clear height	Distance between floor and bottom of door leaf when door is fully opened
OH	Over height	Vertical space required above the clear height
TS	Total space requirement	Distance between outer side of jambs
TW	Total width	Distance between the left and right vertical installation surfaces.
CW	Clear width	Clearance distance between the left and the right guide rails.
MD	Motor depth	Depth of the header box + gear motor + extra space for hand crank
A		Door leaf thickness
B		Minimum free space required for fabric folding
C		Distance from rear side of header box to guide rail centre

4.5 Spare requirements for header box

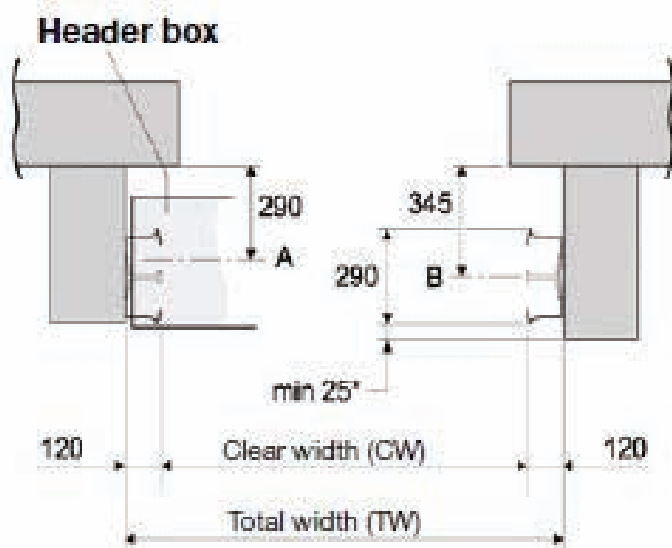

*If outside of external wall

A = Centre line header box

B = Centre line door leaf and guide rail

4.6 Space requirements for operation

In contrast to other types of doors, the Megadoor S1500 vertical fabric folding door requires only limited top and side space. The door leaf is compressed when opened. Even for a large door, the requirements are minimal.

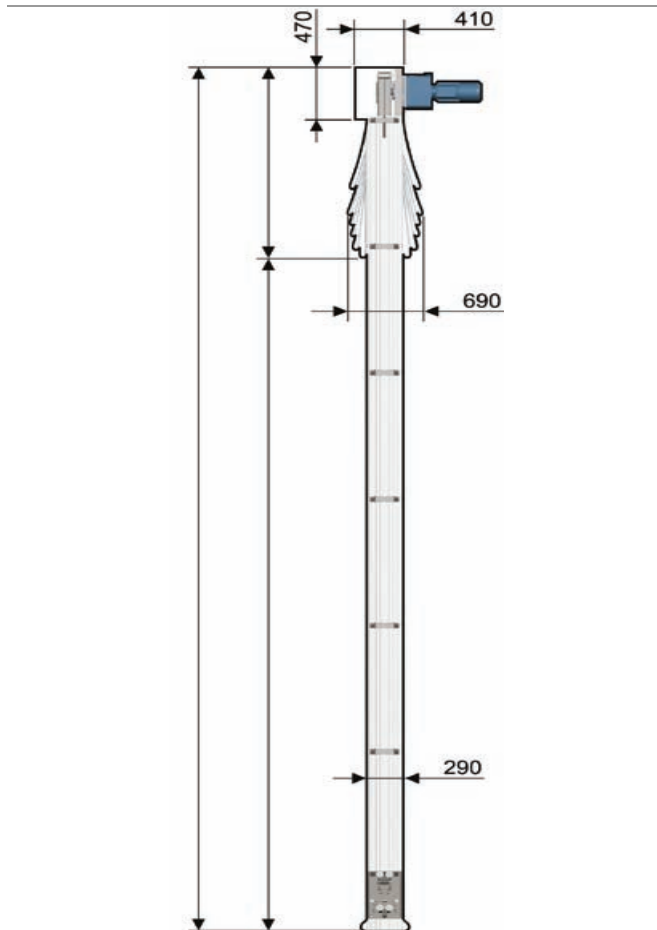

The difference in height caused by different widths, wind loads and motor types makes it impossible to stipulate simple formulas for height calculations. Contact Megadoor for information.

4.7 Space requirements for control unit

The following dimensions (w x h x d) may be of assistance in deciding where to place the control cabinet, possible additional cables or an additional safety switch for the power supply:

Door control	0451
Control unit size (carbon steel or stainless steel)	400 x 500 x 200
Space requirements including brackets	600 x 700 x 220



4.8 Space requirements for maintenance

Space requirements for maintenance (mm)

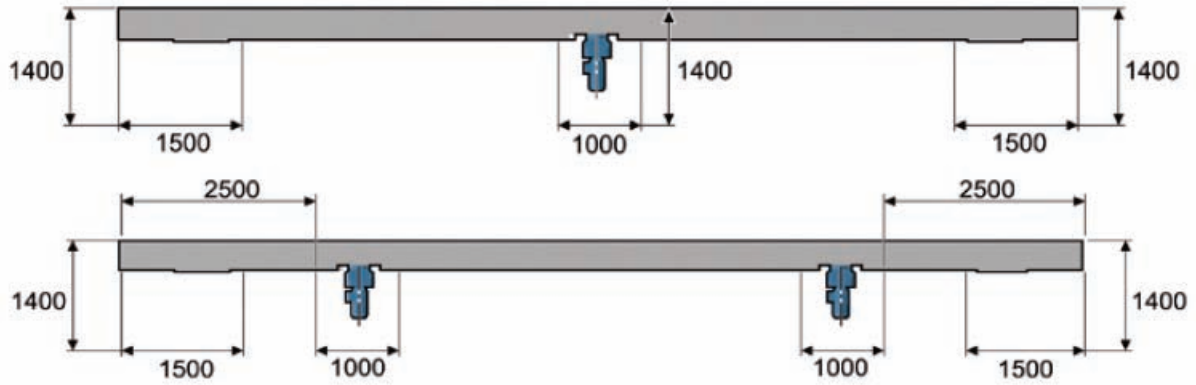

5. Index

A

Additional tests 16
Arctic fabric 12

B

Bottom section 6

C

CEN Performance 16
Clear width and clear height 11
Colors 7
Construction 6
Control unit 10
Copyright and Disclaimer
Notice..... ii

D

Description..... 5
Door leaf..... 6, 12
Door leaf material 7
Drive unit..... 10
Dust proof limit switch boxes. 8

E

Electrical operation 9
Enclosed 9
Enclosed motor side 9
Enclosing the header box 9
Environmental tolerance 11

F

Fabric data 12
Features iii
Fitting against wall on
inside/outside of opening 17
Fitting in door opening 18

G

General 5
General specifications 15
Guide rails..... 8

H

Header box options..... 8
Header box 8
Heat resistant fabric -
Aluminium coating 14
Heat resistant fabric -
Polyurethane coating..... 14
Heat resistant fabric - Silicone
coating 13
Heater in limit switch boxes ... 9

I

Installation of the control unit
..... 21
Installation of the guide rails 21
Installation of the header box
..... 17
Installing System 17

L

Lifting belts..... 10
Load on the building with
door closed..... 18
Load on the building with
door open 18

M

Mount in opening (alt. 2)..... 19
Mounting alternatives for
guide rails 20
Mounting on wall (alt.1) 19
Mounting surface for guide
rails 20
Mounting surface for header
box..... 19

O

Operating system..... 9, 15
Optional colors 7
Options..... 5, 8

P

PDS - Building preparations
..... 17
Performance..... iii, 11
Protective casing over motor
(extra)..... 9

R

Resistance to windload 16

S

Safety arresters 6
Security fabric 14
Service 24
Sound reduction fabric..... 13
Space requirements 21
Space requirements for control
unit 22
Space requirements for
maintenance 23
Space requirements for
operation 22
Spare requirements for header
box 21
Standard..... 5
Standard colors..... 7

Standard fabric..... 12
Surface treatment 11

T

Technical facts iii

V

Vision panels 15

W

Wind locking 7

Megadoor is a world-leading ASSA ABLOY brand focusing on solutions for exceptional access needs within specific industry segments such as Aviation, Shipyard, Mining, Waste and Recycling.

Megadoor is represented in more than 30 countries and is part of ASSA ABLOY Entrance Systems, which also includes the globally recognized Crawford and Besam brands.

www.megadoor.com

